

Characterization of a set of Cryocooled Sapphire Oscillators at the 10^{-16} level with the three-cornered hat method

Christophe Fluhr, Serge Grop, Timothée Accadia,
Ahmed Bakir, Yann Kersalé, Enrico Rubiola and
Vincent Giordano
FEMTO-ST Institute
Besançon, France
Email: giordano@femto-st.fr

Benoît Dubois
FEMTO Engineering
Besançon, France

Abstract— In this paper, we present the characterization results of three Cryogenic Sapphire Oscillators (CSO) by using the three-cornered hat method. The three-cornered hat method permits us to extract the individual frequency instabilities. Thus this powerful tool helps us to choose the best mechanical and thermal CSO configurations. We tested two frequency counters requiring two different data processing and get almost the same results. The three CSOs reach a frequency instability better than 7×10^{-16} between 1 s and 3,000 s integration times. The Allan deviation of the best CSO reaches a noise floor around 1.5×10^{-16} at 200 s integration time. Although, the new CSO incorporates a Kyropoulos instead of a HEMEX sapphire resonator, it presents the almost the same frequency stability than the two other ones.

I. INTRODUCTION

The latest improvements of the Cryogenic Sapphire Oscillators (CSO) were realized in the frame of the ULISS project [1] and presented during the last EFTF in Neuchâtel [2]. Since, a third instrument, codenamed Absolut, was built. This set of three nearly identical CSOs is a part of the OSCILLATOR-IMP platform [3]. It constitutes a unique tool permitting to reach an unprecedented noise floor in frequency stability measurement. Their deployment is not totally finished: only the first CSO is completely optimized. At this step the three-cornered hat method has been applied to extract the CSO individual instabilities, which will help to determine the best CSO configuration. Indeed although the 3 CSOs are based on the same principle they slightly differs from design details and are in different state of progress.

II. CSO DESIGNS

A. Cryogenic Sapphire Oscillator

The CSO incorporates a frequency reference constituted by a whispering gallery mode sapphire resonator placed in the center of a cylindrical copper cavity that can be cooled down to 4 K. High order whispering gallery modes that can be excited in this resonator are characterized by a high energy confinement in the dielectric due the total reflection at the vacuum-dielectric interface. The different resonators we

designed operate on quasi-transverse magnetic whispering gallery modes as $WGH_{m,0,0}$ where m is the number of wavelength in the resonator along the azimuth. The sapphire resonator is placed into a cryostat and in thermal contact with the second stage of a pulse-tube cryocooler delivering typically 0.5 W of cooling power at 4 K. The resonator temperature can be stabilized above 4 K at $\pm 200 \mu\text{K}$. Providing the azimuthal index is sufficiently high ($m > 13$ typically) the Q factor can achieve 1×10^9 at the liquid-He temperature. The CSO is basically a transmission oscillator: the two-port cryogenic sapphire resonator being inserted in the positive feedback loop of a microwave amplifier. A Pound-Galani and a power servos complete the system to control the phase and the power of the oscillating signal.

In our most advanced CSO, a 54 mm diameter and 30 mm thick resonator is operated on the $WGH_{15,0,0}$ mode. The frequency of the $WGH_{15,0,0}$ mode is intentionally set to 10 ± 4 MHz off the nominal 10 GHz [4]. The CSO synthesizer output can be adjusted precisely with a DDS [5].

B. New cryostat

The development of a third CSO was the opportunity to tests other designs and materials. The new cryostat has been developed by Absolut System [6] in collaboration with FEMTO-ST. Absolut is shown in figure 1. It is based on a PT407 Cryocooler from Cryomech, which is more powerful than the two others CSOs equipped with PT405. Conversely to the two first ones, the mechanical decoupling of the cryocooler head (bellows) is implemented. The internal mechanical decoupling is realized with copper foil thermal straps instead of copper braids. This cryostat also incorporates different copper thermal shields (instead of aluminium covered with MLI). A thermal ballast is placed between the resonator and the 2nd stage of the Pulse-Tube to filter temperature fluctuations.

Absolut incorporates a Kyroupolos sapphire crystal provided by the company Precision Sapphire Technology

(PST) [7] instead of the common HEMEX sapphire resonator [8]. This resonator is a preliminary version attended to test another source of high quality sapphire crystals. To limit the cost of this very preliminary sample, its mechanical tolerances were relaxed leading to a higher offset frequency. Moreover the resonator is just a sapphire cylinder with a 5 mm hole along its axis. A screw passing through is used to maintain the sapphire in the cavity. In the two other CSOs, the resonator is equipped with a spindle, which limits the stress induced in the effective resonator volume. A higher long-term drift is expected with the simple Absolut resonator mounting. Unloaded Q-factors as high as 700 million have been observed in preliminary experiments. The current resonator adjustment is totally optimized and the loaded Q-factor is 400 million. Eventually and in order to test different components, the oscillating loop has been implemented on a table and linked to the cryostat with commercial microwave 1m length cables. It thus experiences all the temperature variations and vibrations of the experimental room.

The status of each CSO is given in the table I.

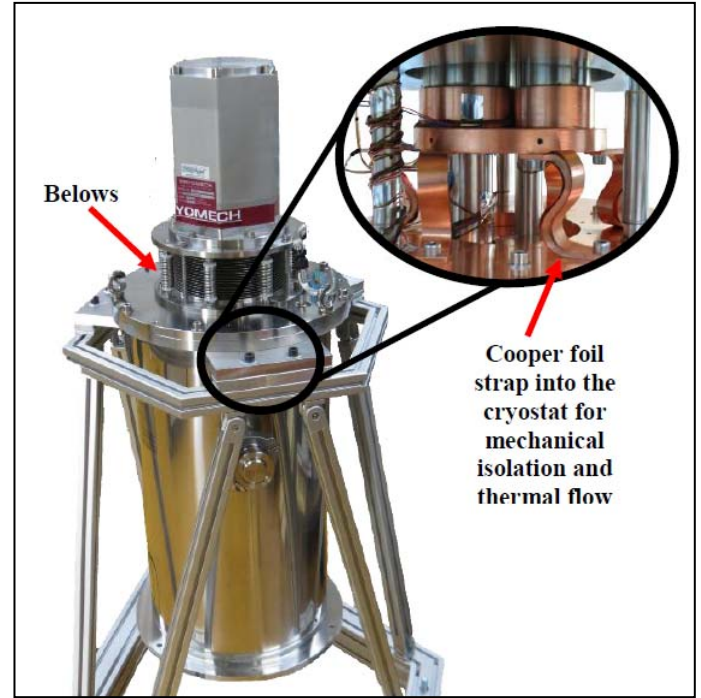

Fig. 1. Mechanical and thermal Cryostat specifications

TABLE I. MAIN CHARACTERISTICS OF EACH CSO

Characteristics	Marmotte	Uliss	Absolut
Frequency	9.988 GHz	9.995 GHz	9.962 GHz
Loaded Q factor	1 Billion	350 Million	400 Million
Crystal type	HEMEX	HEMEX	Kyropoulos
Turnover point temperature	6.2379 K	5.7656 K	5.2217 K
Cryocooler	PT405	PT405	PT407
Cryostat manufacturer	Oxford Instruments	Oxford Instruments	Absolut System
Thermal Ballast	No	Yes	Yes
Status	Optimized	Resonator needs cleaning and coupling adjustment	Resonator needs cleaning and coupling adjustment. Oscillating loop on table

III. THREE-CORNERED HAT

A. Setup and data acquisition

With this third CSOs, Absolut, we implement three-cornered hat method [9]. This method is useful for determining the individual stabilities of units having similar performance. Despite the three oscillators have a different design of cryostat, we expect that their noises level are equivalent. Each has a different frequency, this one being specific to sapphire dimensions. The three beatnotes frequency are obtained by mixing the output of each CSO with the two others CSOs. In order to not be limited by the counter's resolution we chose to increase the heterodyne factor of the two beatnotes Absolut-Marmotte and Absolut-Uliss. We make a down conversion by mixing beatnotes with a signal from a direct digital synthesizer (DDS). DDSs are clocked on a 100 MHz MASER source manufactured by T4Science [10]. This three beatnotes are connected to a frequency distribution amplifier product by Timetech [11]. The frequencies are counted by two different instruments, the K+K FXE SCR and the GuideTech GT668. The entire setup is described on Fig 2.

a) *K+K FXE SCR*: is a multi-channel phase recorder [12]. It uses the picket fence measurement method. Frequency is determined by counting period's occurrences during a certain length of time. Reference signal defines the time interval. All channels are operated in the same time. The sampling rate is 1,000 samples per second. An averaging is applied to get one data per second for each channel. This averaging permit to increase the resolution. All data are post-processed on Stable32 to extract frequency stability of each CSO.

b) *GuideTech GT668*: is a high-speed continuous time interval analyzer (CTIA) which logs the time of occurrence of

events at its inputs [13]. Event are defined as a signal voltage crossing a specified threshold. These 'time-tags' are used to calculate the signal frequency over any time windows τ (1 s in our case) and with no dead time. In order to improve the GT668 resolution, the processing involves a triangular averaging of frequency measurements. The sampling rate is 40,000 samples per second and could be improve to 4 MSa/s [13]. The instrument have only two input channels which seems to be a problem for three-cornered hat method. A third 'virtual' channel is generated by software. Equation (1) shows the relative frequency stability, σ , of one channel with three devices A,B,C described how to the third channel is reconstructed.

$$\sigma_{AB}^2 = \sigma_A^2 + \sigma_B^2 \quad (1)$$

Then with two channels, the third can be reconstructed with :

$$\sigma_{AC}^2 = \sigma_{AB}^2 - \sigma_{BC}^2 \quad (2)$$

according that all CSO are totally uncorrelated. The implementation of this instrument is only on preliminary startup. We use Stable32 to calculate the Allan deviation.

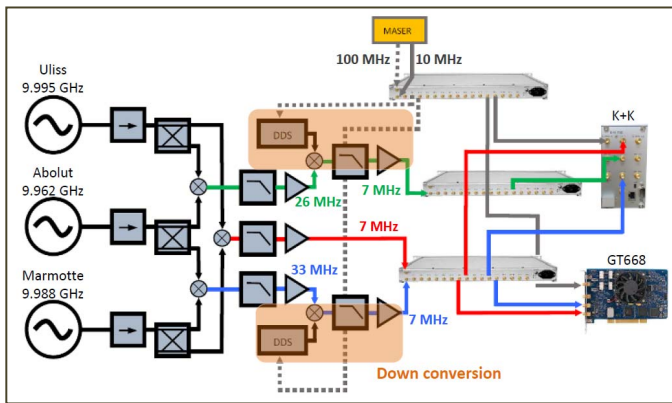

Fig. 2. Measurement setup.

II. RESULTS

The results of individual Allan deviation for the three CSOs are given in Fig. 3 concerning the K+K, the data are drift removed.

Three-cornered hat show us that Marmotte reaches a noise floor about 1.4×10^{-16} at 100 s integration time. The difference between the oscillators from 1 s to 500 s, could be explain by the Q factors variation. All CSOs are equivalent at 1 s integration about $\sigma(1s) = 5$ or 7×10^{-16} . For Uliss, the hump at 8 s is due to the sapphire temperature regulation. A better adjustment of the control loop parameters should reduce the effect. We notice that the three oscillators present a long term drift after 1,000 s, it is the effect of room's air conditioning. The values of Allan deviations are given in table II.

The shapes given by the GuideTech's results are equivalent. Nevertheless the values are slightly different. The first possible origin of error is that the data were not acquired at the same time. The second source of error is the data post processing of the GT668's. The preliminary results are traced on Fig. 4.

TABLE II. ALLAN DEVIATION OF THREE CSOS

Integration time τ in second	Allan Deviation $\sigma_y(\tau)$		
	Marmotte	Uliss	Absolut
1	7.32×10^{-16}	5.27×10^{-16}	7.29×10^{-16}
8	3.98×10^{-16}	6.45×10^{-16}	4.55×10^{-16}
64	2.38×10^{-16}	3.82×10^{-16}	4.32×10^{-16}
256	1.55×10^{-16}	4.58×10^{-16}	6.55×10^{-16}
1024	3.81×10^{-16}	1.08×10^{-15}	1.00×10^{-15}

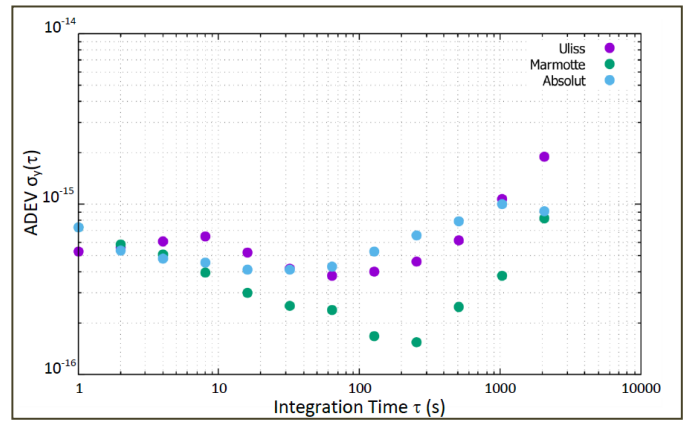

Fig. 3. Allan deviation for each CSO from K+K.

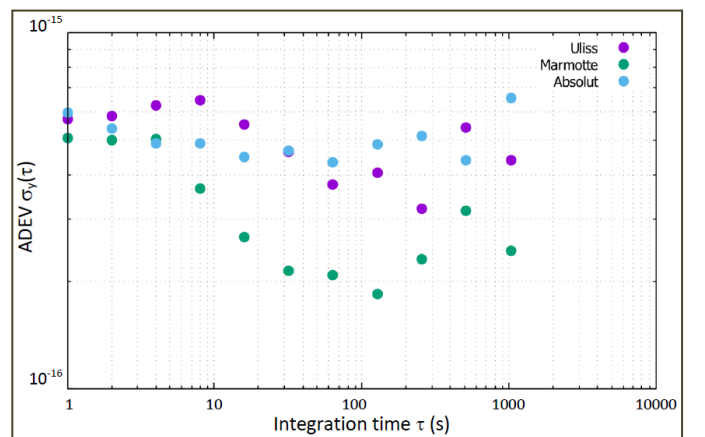

Fig. 4. Allan deviation for each CSO from GuideTech.

III. CONCLUSION

The results show an Allan deviation of 1.5×10^{-16} at 100 s integration time measured. Two instruments were used. The three-cornered hat method allows to discriminate among the CSO characteristic offering new possibilities to improve CSOs performances. Thereby different solutions can be tested and analyzed. This solutions may concern the thermal configuration, the mechanical design or even the oscillator control. It will be possible to reach better frequency stability by combining the best choices. The startup of our new CSO, Absolut, allows us to propose an alternative cryostat design. This oscillator achieve the same results than the two others.

Acknowledgment

The authors would like to thank the Programme Investissements d'Avenir (PIA).

References

- [1] <http://www.uliss-st.com/>
- [2] Serge Grop, Christophe Fluhr, Benoit Dubois, Jean-Louis Masson, Yann Kersale, Enrico Rubiola, Gregory Haye and Vincent Giordano: *Latest Improvements in the Performances of a Cryogenic Sapphire Oscillator*, Proceedings of the 2014 EFTF, 23-26 June 2014, Neuchâtel (CH)
- [3] See <http://theta.obs-besancon.fr/spip.php?article212>: for details on the OSCILLATOR-IMP Project (<http://oscillator-imp.com> coming up next).
- [4] S. Grop, P.Y. Bourgeois, N. Bazin, Y. Kersalé, E. Rubiola, C. Langham, M. Oxborrow, D. Clapton, S. Walker, J. De Vicente and V. Giordano. *ELISA : a cryocooled 10 GHz oscillator with 10^{-15} frequency stability*. Review of Scientific Instruments , 81, 025102 (2010).
- [5] S. Grop, P.Y. Bourgeois, E. Rubiola, W. Schafer, J. Devicente, Y. Kersalé and Giordano V. *Frequency Synthesis Chain For The ESA Deep Space Network*. Electronics Letters, 47, n°6, pp. 386-388, 2011
- [6] Absolut System SAS: <http://www.absolut-system.com/>
- [7] Cryomech, incorporation: <http://www.cryomech.com/>
- [8] Precision Sapphire Technologies, Ltd.: <http://www.sapphire.lt>
- [9] J.E. Gray and D.W. Allan, *A Method for Estimating the Frequency Stability of an Individual Oscillator*, Proceedings of the 28th Annual Symposium on Frequency Control , May 1974, pp. 243-246.
- [10] TimeTech GmbH , “Frequency Distribution Amplifier” Part N°:10274 datasheet, March 2006
- [11] C. E. Calosso, E. Rubiola, *Phase noise and jitter in digital electronics*, Proceedings of the 2014 EFTF, 23-26 June 2014, Neuchâtel (CH)
- [12] T4Science: <http://www.t4science.com/>
- [13] G. Kramer and W. Klische:*Extra high precision digital phase recorder*, European Frequency and Time Forum, 2004
- [14] <http://www.guidetech.com>